

1 - What best describes your business?  
 Retail Service 2 6 1 1 1 1  
 Professional: Manufactur: Agricultura Other 1 1 1 1

# Business Descriptions

Retail 
  Service 
  Professional 
  Manufacturing 
  Agricultural 
  Other

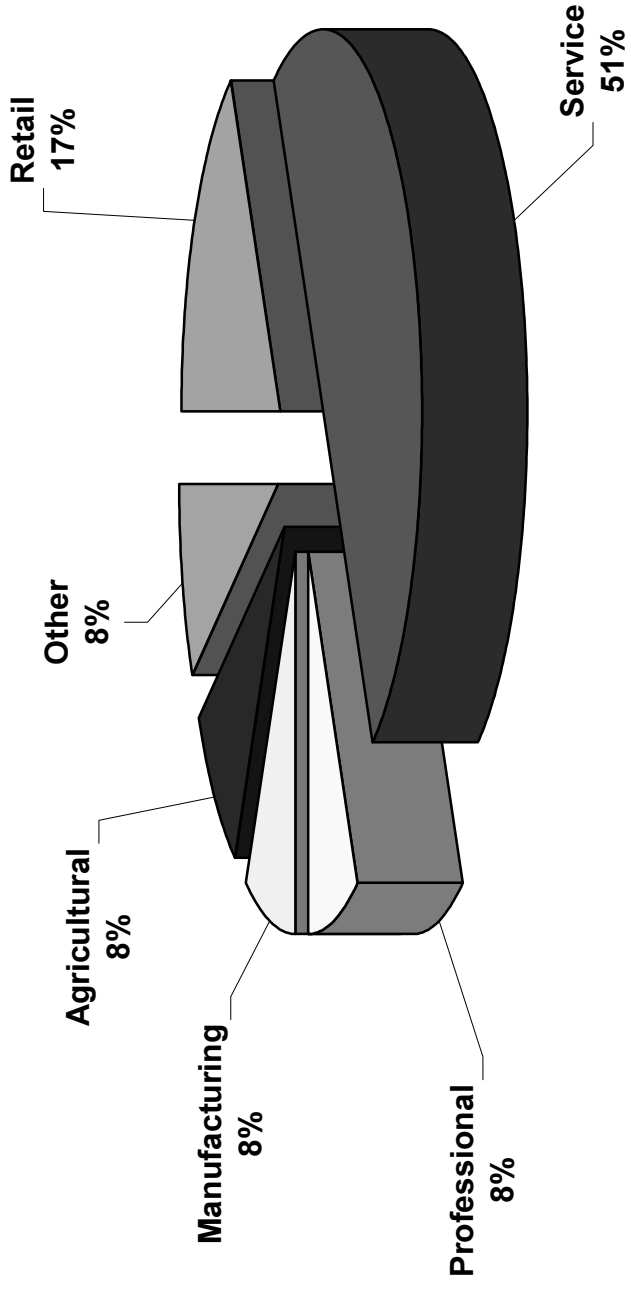

2 - What year was your business established?

1916 1 1917 1 1946 1 1950 1 1956 1 1982 1 1989 1 1990 1 2002 No Response 2

# Year Business Established

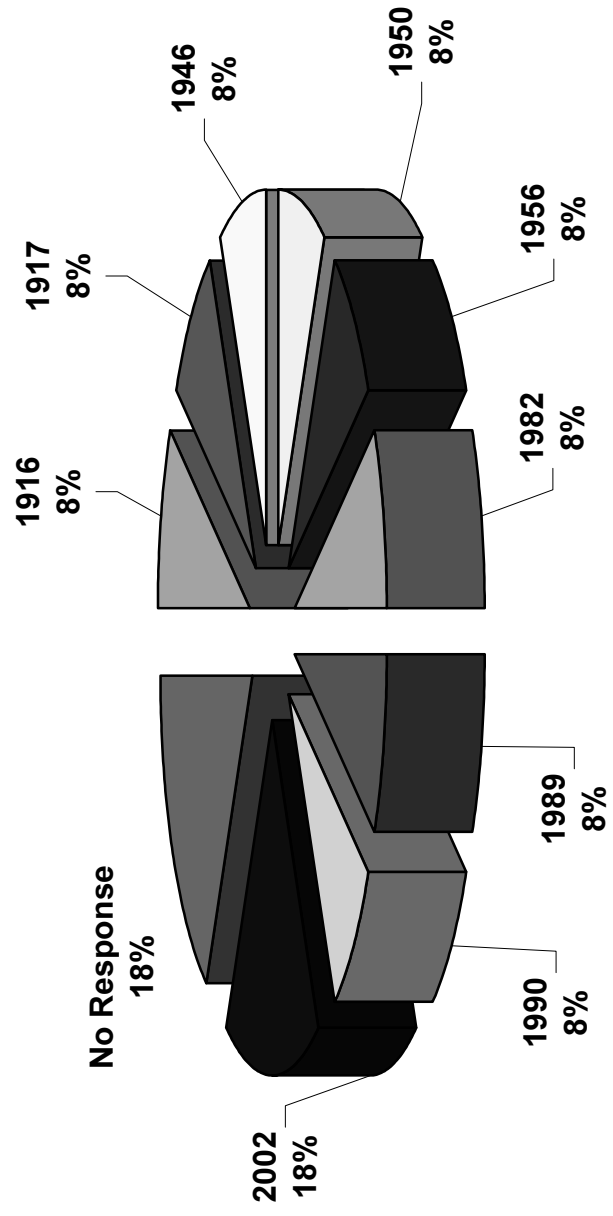
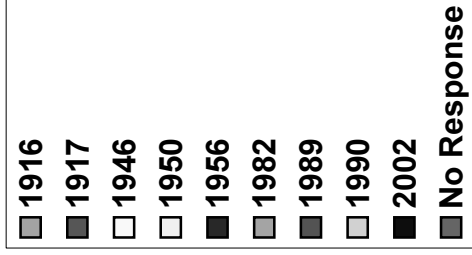

3 - How long has your business been in the Village of Granville?  
 1 Year or Less 1 2 3 4

## Years in Business

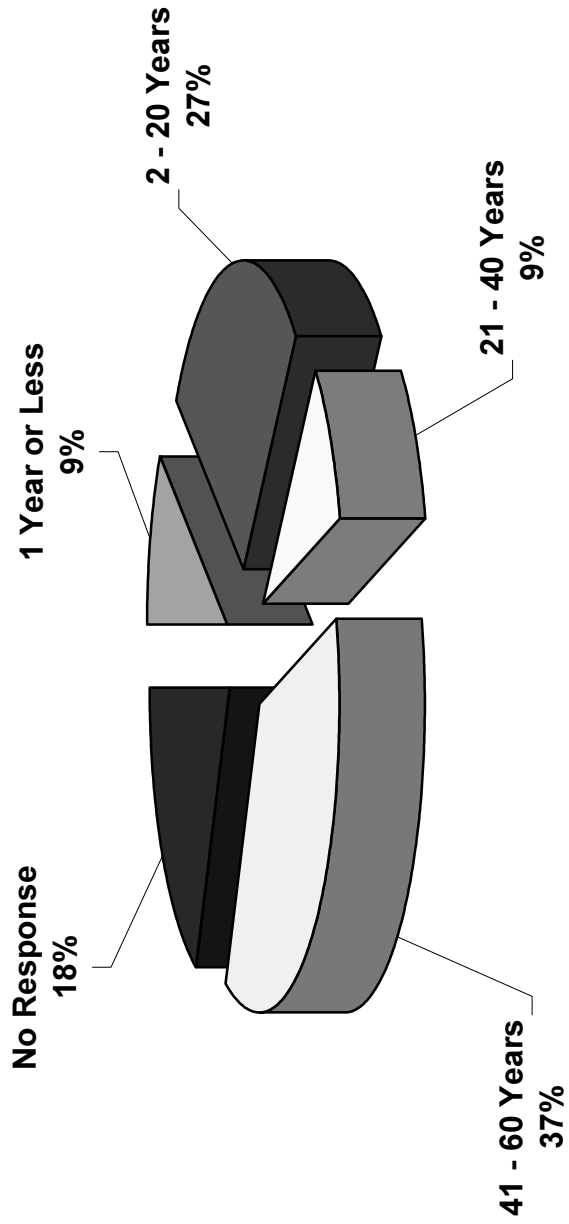
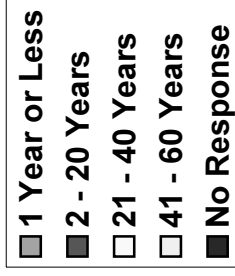

4 - How many people do you employ?

Full-Time	Part-Time	Seasonal
135	30	1

## People Employed

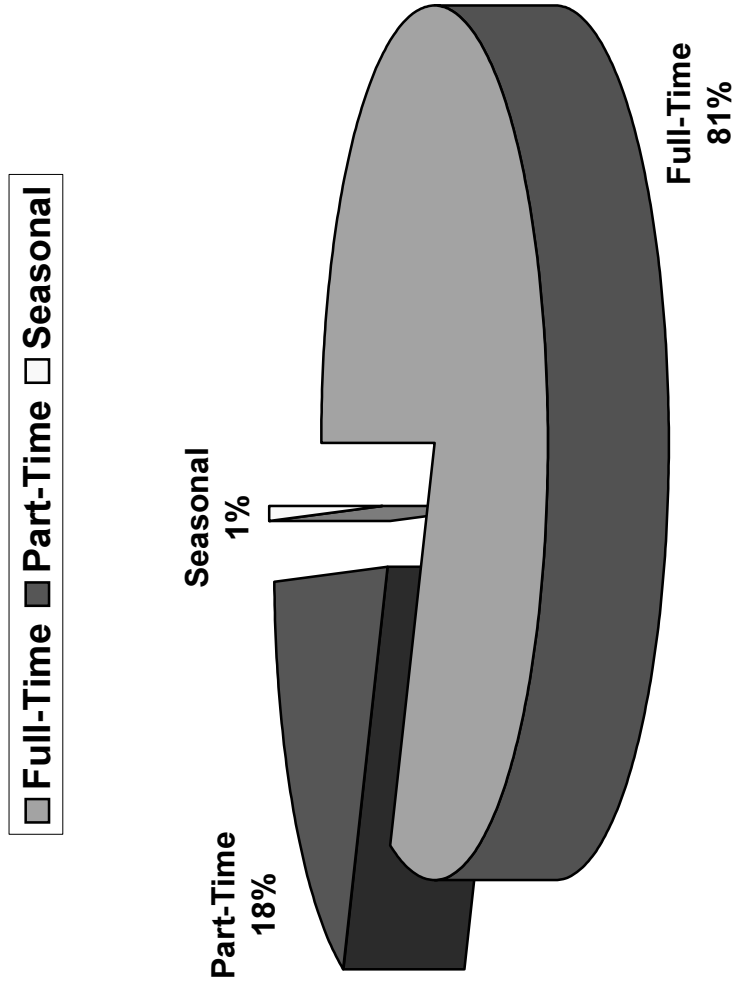

5 - What is the salary range of your employees?  
 Under \$10,000 - 1  
 \$10,000 - \$19,999 - 3  
 \$20,000 - \$29,999 - 4  
 \$30,000 - \$39,999 - 3  
 Over \$40,000 - 3

## Salary Range of Employees

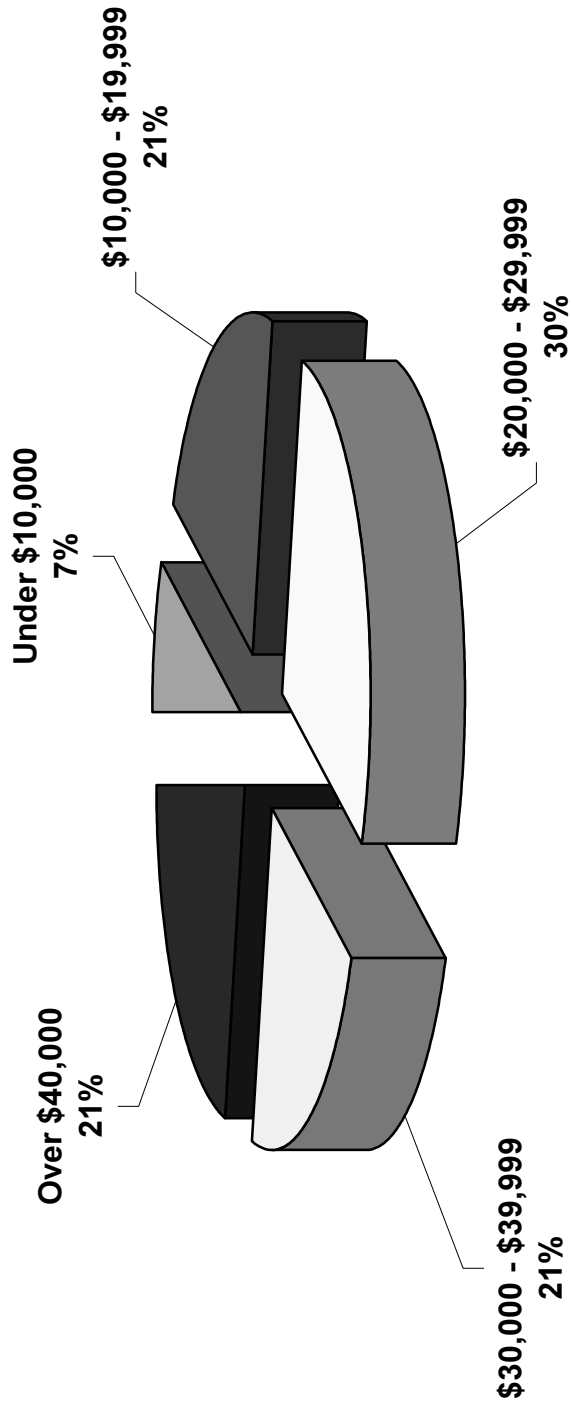
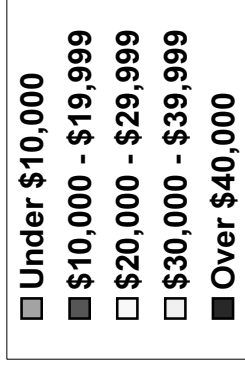

6 - Do you live in the Village?

Yes

3

No

9

## Live in the Village

■ Yes ■ No

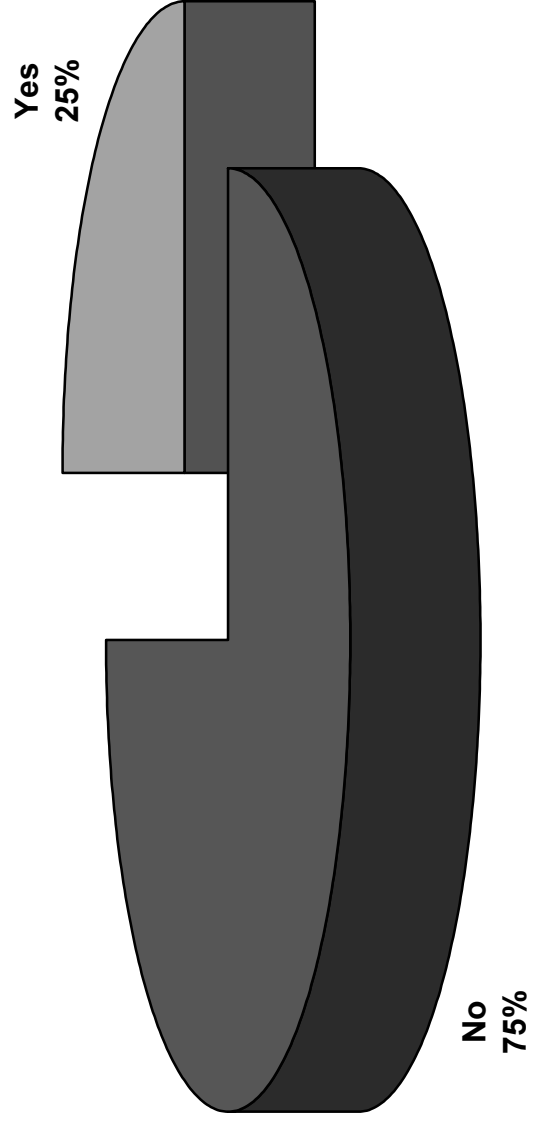

7 - Do you own or rent your place of business?

Own      8  
Rent     3  
No Response   1

## Own or Rent Business

■ Own   ■ Rent   □ No Response

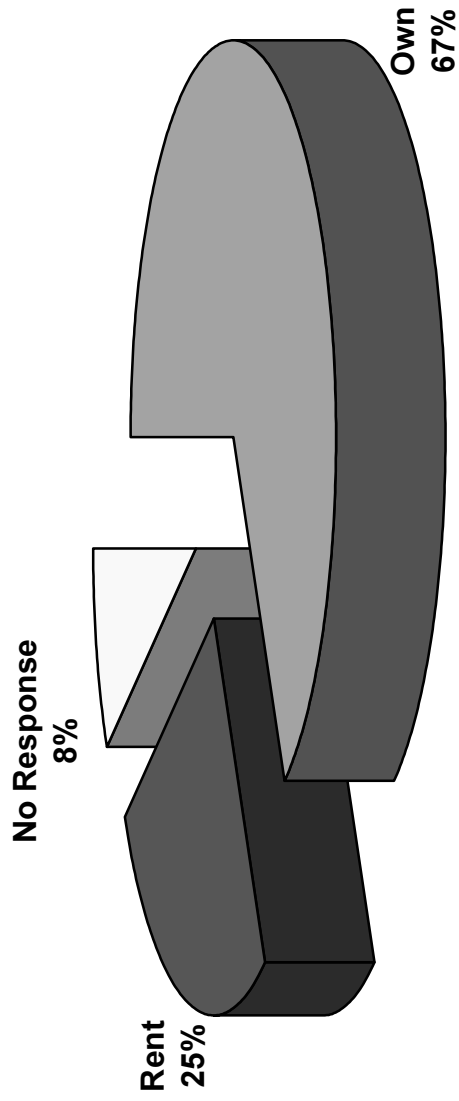

8 - What percentage of your customers are tourists?  
 0% 1% - 5% 15% 20% 30% No Response  
 3 5 1 1 1

## Percentage of Customers are Tourists

0% 1% - 5% 15% 20% 30% No Response

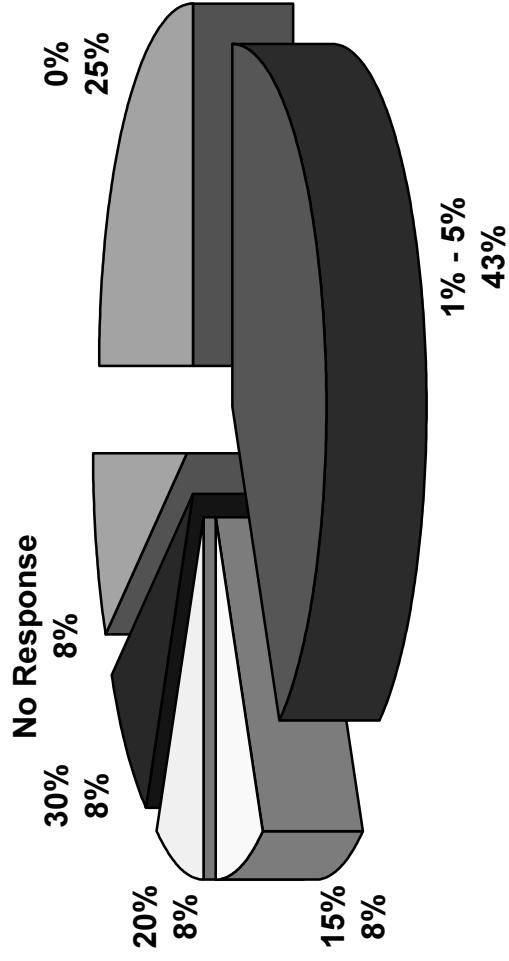

9 - In the past five years have your sales?  
Increased 5    Decreased 4    Stayed the Same 1    No Response 2

## Sales for the Past Five Years

Increased    Decreased    Stayed the Same    No Response

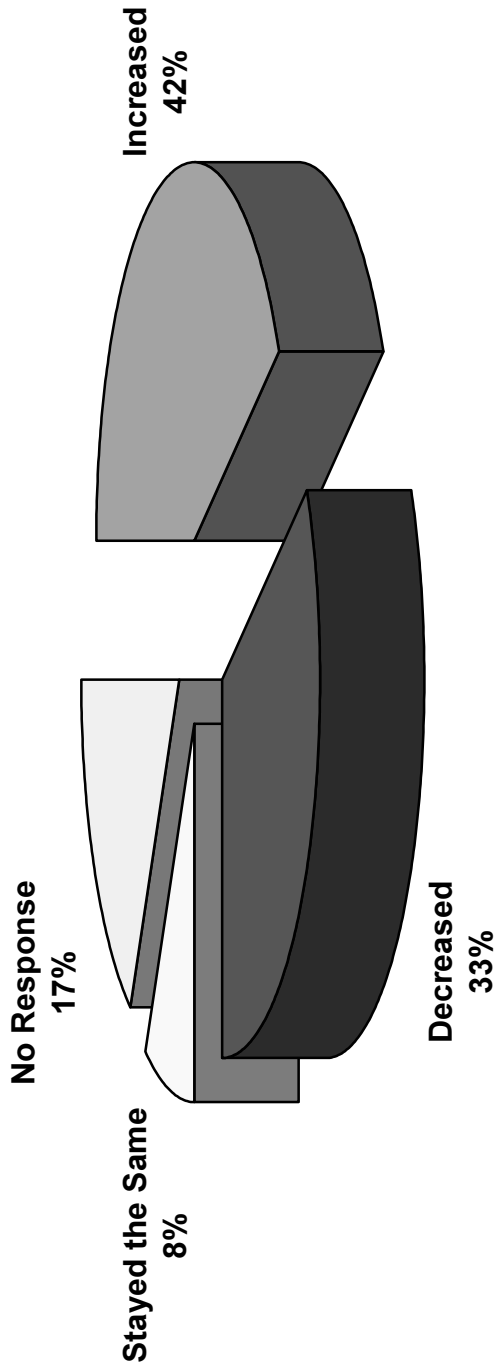

10 - Do you intend to expand in the next year or two?  
Yes 2 No 8 No Response 2

## Expand in the Next Year or Two

Yes  No  No Response

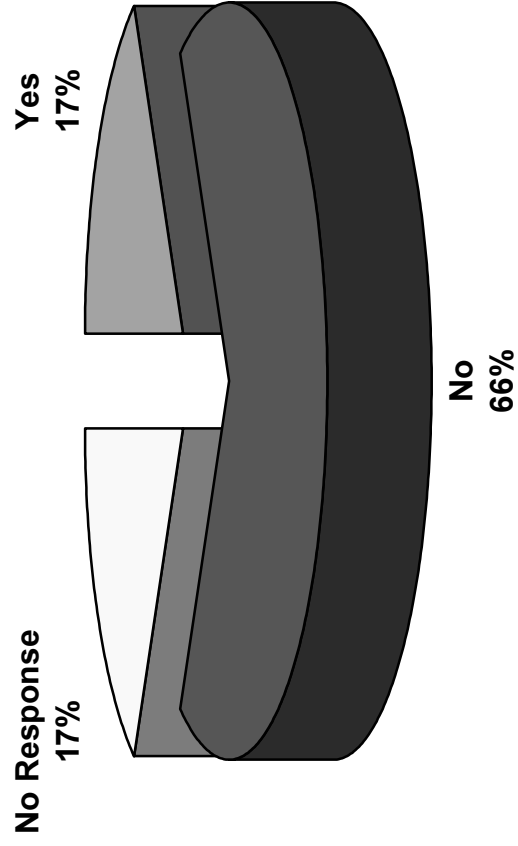

11 - What factors or amenities of the Village are beneficial to your business? Please list and/or explain as many as you can

- 3 Water
- 2 Sidewalk Plowing
- 1 Active Mayor
- 1 Shopping Area
- 1 Street Cleaning
- 1 Quiet
- 1 Library/Museum
- 1 Community Service
- 1 Snow Removal

12 - What factors or amenities of the Village adversely affect your business? Please list and/or explain as many as you can

- 3 Parking
- 2 Empty Buildings
- 1 Losing Department Store
- 2 Loitering
- 1 Whole Town needs face lift
- 3 Taxes
- 1 Messy

13 - What would you like to see changed in the Village? List any and all factors, such as road design, traffic signs, façade improvement, increased community spirit etc.

- 1 Enforce Loitering
- 1 Need more Police on Main Street
- 3 Sidewalks and Lighting
- 2 Facades Improvements
- 1 Tax Breaks for Local Business
- 1 Safety
- 1 Change in Streets
- 1 Community Spirit

14 - What do you see as some of the main benefits of doing business in Granville? In other words, what makes you stay in Granville?

Close, Caring & Loyal Community

Location

Nothing

Major Employers

Low Crime

Bank

The Hub

15 - What services/goods do you provide?

1 Rebuilding Stage

1 Deserts & Food Dishes

1 Personal Fitness

1 Motel

2 Medical Care

1 Florist

16 - What services/goods do you think are needed in the Village but not provided now?

5 Clothing

1 Promoting Smaller Stores

2 Nice Restaurants

2 Discount Food

1 Health Food

1 Excellent Schools

1 Reception Hall

1 Cell Phone Service

17 - Please rate the following services that are provided by/to the Village?

	Excellent	Good	Fair	Poor	Unknown
Fire Protec	6	3	2		
Police Prot	6	5			
Sidewalk/R	1	9		1	
Water/Sew	4	6	1		
General Ti	2	5	4	1	
Planning Board	1	1	2	1	5

## Rate Services Provided by/to the Village

■ Excellent ■ Good □ Fair □ Poor ■ Unknown

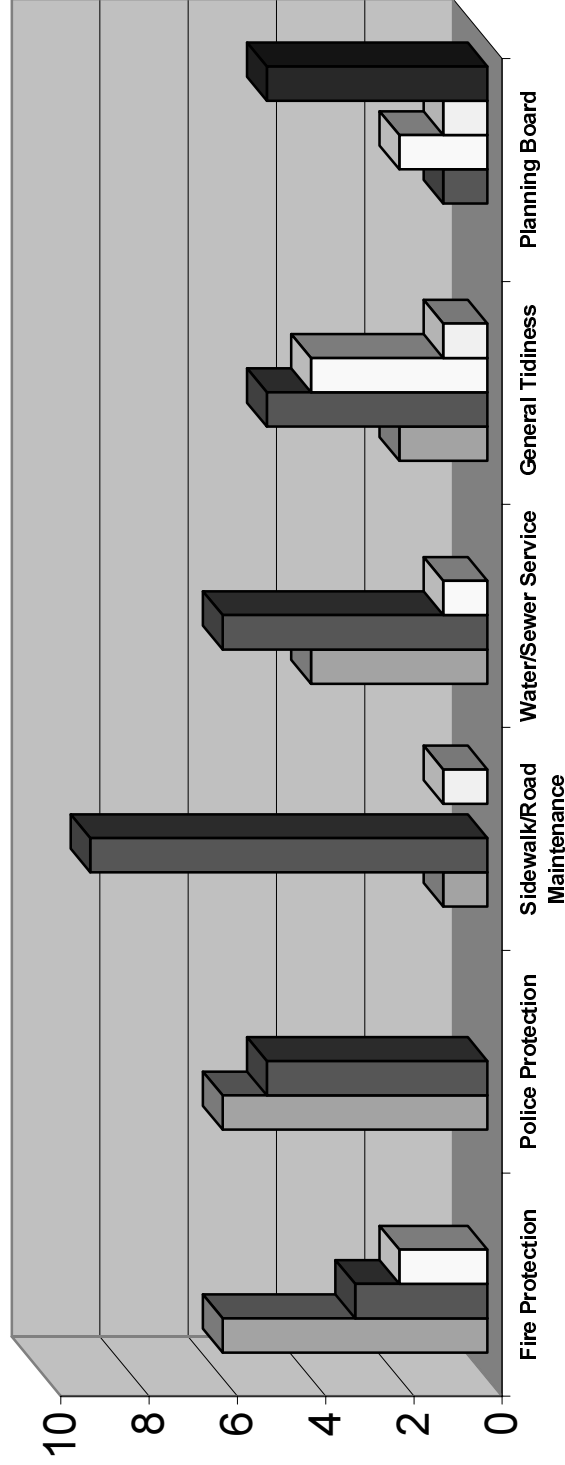

18 - Is the Village Government responsive to the needs of the business community?

Yes 3    No 2    Unknown 6    No Response 1

## Responsive to the needs of the Business Community

Yes    No    Unknown    No Response

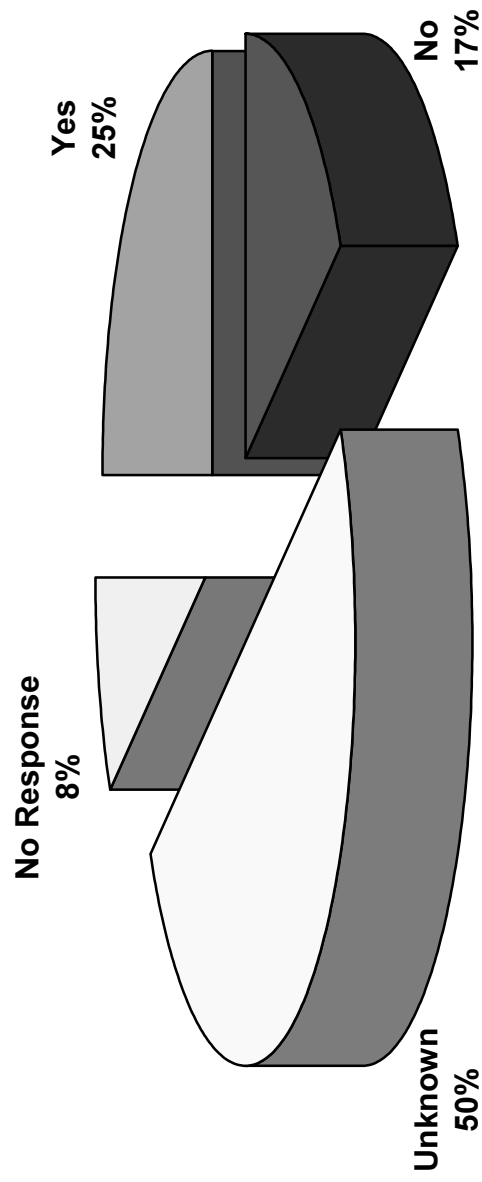

19 - Please add any other comments you feel would be helpful in the development of a Comprehensive Plan.

- 1 Change
- 1 Less Signs around Village
- 2 Clean & Welcoming entry to Village
- 1 More Business
- 1 More input from Community
- 1 Minimizing Commercial/Industry Development in Residential areas